

Expansive behaviour of a sulphated clay in a railway tunnel

Comportement gonflant d'une argile riche en sulfates dans un tunnel de voie ferrée

E. Alonso, A. Gens, I. Berdugo & E. Romero

Department of Geotechnical Engineering and Geosciences, Universitat Politècnica de Catalunya, Barcelona, Spain

ABSTRACT

The paper presents the case of a railway tunnel excavated in sulphate-bearing clays in which large expansive phenomena were observed during construction. Field data and laboratory tests results showed connections between some mechanisms of degradation and the swelling behaviour of the foundation material. The paper summarizes the main characteristics of the tunnel and proposes some explanations for the observed behaviour. 100

RÉSUMÉ

L'article présente le cas d'un problème de gonflement qui s'est produit lors de la construction d'un tunnel dans massif constitué des argiles sulfatées. Les données expérimentales de laboratoire et *in-situ* montrent la relation existant entre les mécanismes de dégradation et de gonflement du matériel de fondation. Le texte montre les caractéristiques les plus importantes du tunnel et propose quelques explications pour ce comportement observé.

1 INTRODUCTION

Important deposits of sulphate-bearing hard soils and soft rocks occur in the lower Tertiary Ebro Basin, northeast Spain. These materials range from Early Eocene to Late Miocene in age and consist mainly of clays containing anhydrite, gypsum and carbonates interbedded with limestones and sandstones. Groundwater in the basin is highly mineralized with calcium-magnesium sulphates as principal dissolved salts.

Expansive phenomena in both surface and underground excavations carried out in those materials are often observed. In Ascó II Nuclear Power Station –located in the lower stretch of the Ebro river and founded on sulphate-bearing marls–, heaves were detected immediately after the excavations for the construction of slabs foundations were performed. In a period of ten years since the late 70' maximum floor heave was 60 mm and an additional heave of 40 mm has been predicted for the period 1980-2020 (Lloret et al., 1988; Gens et al., 1993).

Recently, the authors were involved in the analysis of swelling problems which affected a railway tunnel located in the east flank of the Lower Ebro Basin, near Montblanc (province of Tarragona, Catalonia). The tunnel runs mainly through Early Eocene argillaceous deposits containing anhydrite and a very complex system of cross-shaped moderately dipping fibrous gypsum veins. Floor heave as well as swelling pressures in the foundation material developed quickly; however, no expansive problems were detected in the vault. Just as in the case of Ascó, the expansive phenomena in this case were strongly related with degradation of the excavated materials as a result of both unloading and wetting in presence of soluble sulphated minerals.

The purpose of the paper is to present experimental data which illustrate the expansive behaviour of these materials and their dependence on basic degradations mechanisms.

2 GEOLOGY AND TECHNICAL FEATURES OF THE TUNNEL

The tunnel is located in the Lleida-Tarragona section of the new Madrid-Zaragoza-Barcelona high-speed railway. The excavated material consists of a monotonic series of sulphate-bearing brown argillaceous materials. Gypsum is mainly present as millimetric and centimetric fibrous veins, as well as little nodules and flakes (San Dimas, 2002). The existence of a persistent system of slickensided surfaces has been related to strong kneeling

folds produced by the high curvature radius tectonics in the regional Horst (Priorato-Gayá). The chemical composition of the groundwater is presented in Table 1. Thermodynamic analysis showed that under these conditions gypsum tends to precipitates below 10°C.

Table 1: Mean groundwater properties

Macroconstituent	ppm
Sulphates	1783
Bicarbonates	302
Chlorides	39
Carbonates	10
Nitrates	6
Calcium	500
Magnesium	141
Sodium	29
Potassium	3

CE: 2700 $\mu\text{S}/\text{cm}$; pH: 7

The tunnel has a length of 2 km, maximum gradient of 2.5% and overburden varies between 32 m and 120 m. A horseshoe cross-section of 117.3 m² was created by drill and blast excavation from the two portals, dividing the section into advance and bench (see Fig. 1). Temporal supports consisted in sprayed concrete and rock bolts. Steel arch ribs (HEB 160) were only installed in zones of low quality rock. Lining consisted of 300 mm thick casing mass concrete (25 MPa) and a 300 mm thick flat-slab constructed in mass concrete was placed on the tunnel floor (25 MPa).

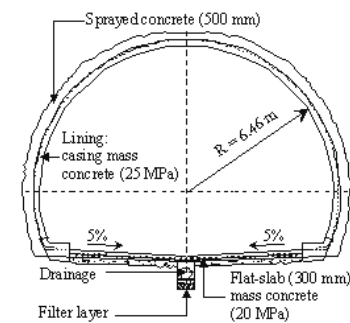

Figure 1. Original cross-section of the tunnel

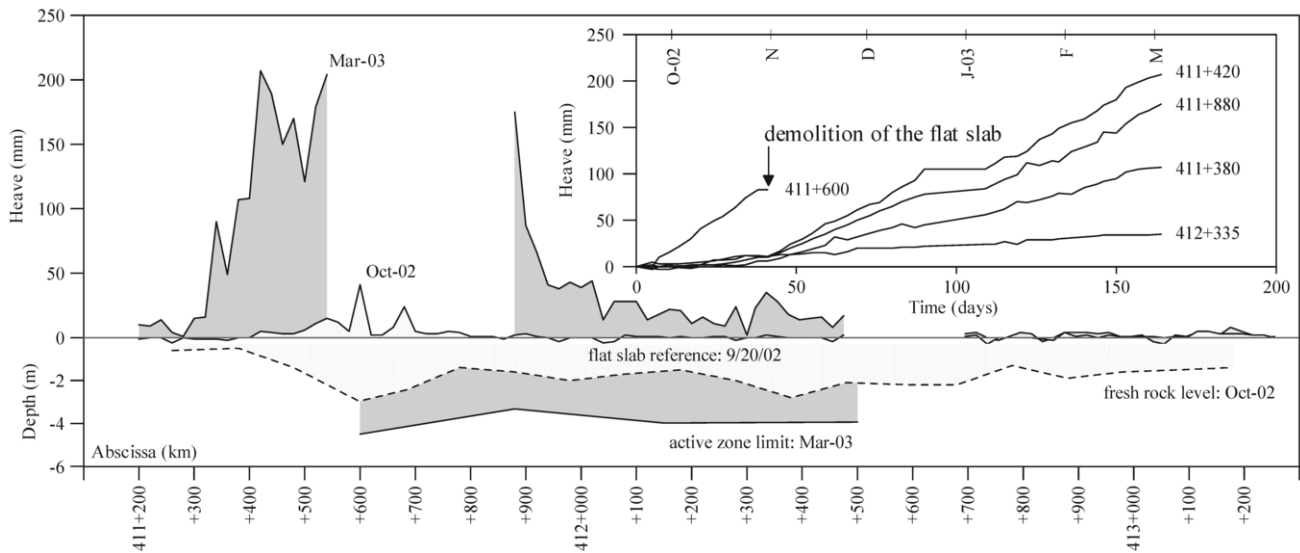

Figure 2. Heave of the flat-slab and their connection with degradation of the foundation material

Due to the low permeability of the massif, waterproofing of the excavated section was restricted to portals using a geotextile of 500g/m² placed over a 1.5 mm thick PVC sheet located between the support and the lining. The longitudinal drainage system was composed of a 500 mm diameter PVC collector located 1 m below the floor. Underneath, a 200 mm gravel filter layer was constructed. Water from the vault was collected in box-type manifolds distributed uniformly along the tunnel floor.

3 EXPANSIVE PHENOMENA

Large expansive phenomena occurred in a generalized way at floor level, but movements were only slight in the vault. The first displacements were detected in the flat-slab in September/October 2002, just after it was built. There were distortions and heaves followed by damages of the longitudinal drainage system and local failures of flat-slabs. Once an invert-arch test section was constructed, high swelling pressures were also measured at the rock-concrete contact.

Figure 2 illustrate the magnitude of the floor heaves and the condition of the foundation material at two different stages of the swelling problems: October 2002 –at the beginning of the monitoring program–, and March 2003 –after the construction of tests sections with invert-arch–.

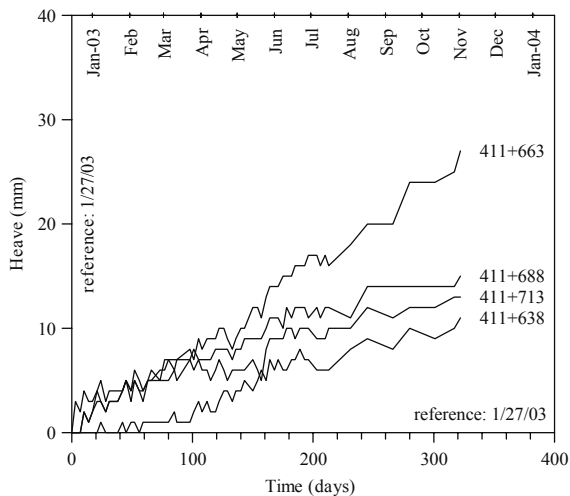

Figure 3. Floor heave in sections with invert

Expansive phenomena in the foundation material evolved systematically at high rates. In December 2003 critical sections with flat-slab (411+420 and 411+880) showed heaves above 600 mm with a rate near 2 mm/day; whereas in the critical section with invert-arch (411+663) a maximum heave of 27 mm was measured 12 months after their construction. In this case, the value of the heave rate was only 0.1 mm/day (see Fig 3). Although invert-arch was designed for pressures smaller than the measured swelling pressures, it was very effective in reducing vertical displacements. Maximum swelling pressures in sections with invert-arch occurred at sections 411+629 and 411+829 (see Fig. 4).

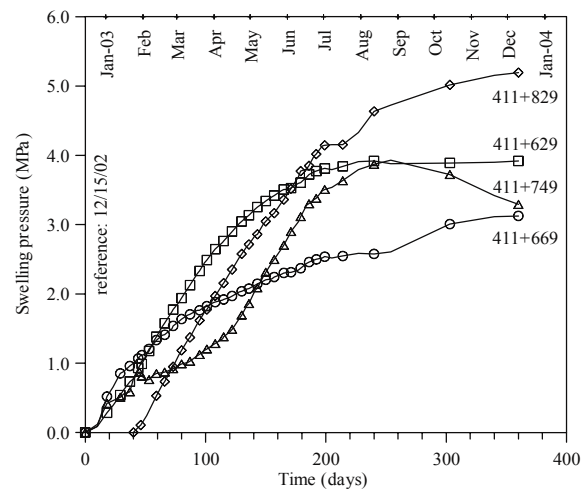

Figure 4. Swelling pressures in sections with invert

4 EXPERIMENTAL PROGRAM

Continuous undisturbed core specimens of the foundation material were recovered during boreholes drilled in October 2002 and March 2003.

A comprehensive set of laboratory tests was performed in order to obtain quasi-continuous profiles of geotechnical properties of the samples, including the distribution of the solid phase among basic constituents. In addition, vertical strain profiles below both flat-slabs and invert-arches were obtained by means of sliding micrometers (see Fig 5).

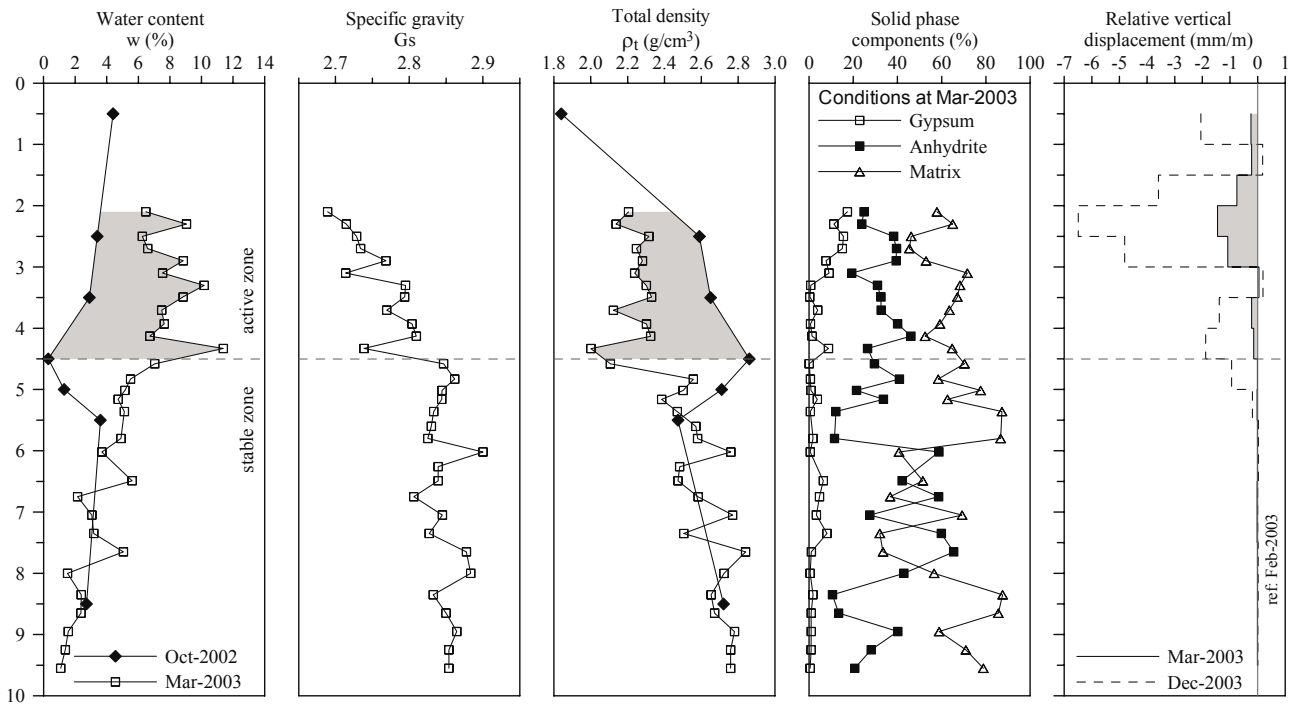

Figure 5. Geotechnical characterization and vertical strain profile of the section 411+600

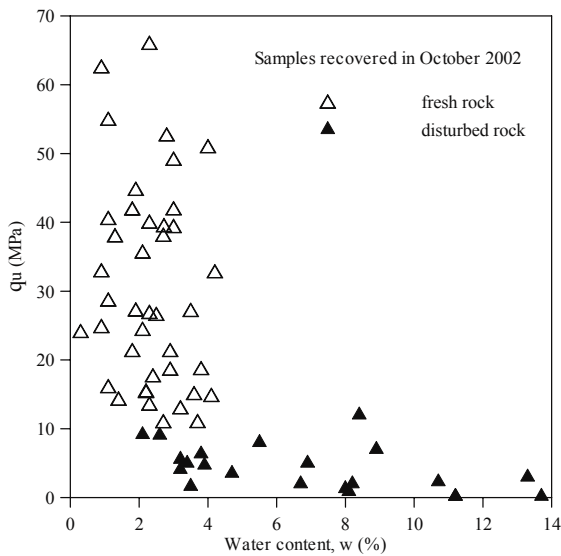

Figure 6. Dependence of unconfined compression strength on water content

5 ANALYSIS OF RESULTS

Two main components were identified in the mineralogical characterization of the material: the host argillaceous matrix and the sulphated crystalline fraction. The first is constituted by phyllosilicates (illite and paligorskite), by minerals rich in magnesium and calcium (dolomite) and, to a lesser extent, by quartz. Expansive clays were only detected in isolated points of the matrix. In those cases kaolinite and stevensite were identified as complementary minerals. The second component is mainly made up of anhydrite and gypsum.

The dependence of the unconfined compression strength on the water content in samples recovered in October 2002 is presented in Figure 6. In this case the loss of strength was unequivocally related with deleterious effects of wetting process in the foundation material due to flow of sulphated water through

fissures and slickensided surfaces opened by the stress relief caused by the unloading.

Sliding micrometers lectures allowed to identify of an active upper zone in the foundation material where expansions accumulated with time (see Fig 2). Particularly, in Figure 5 is shown that expansions in the section 411+600 were associated with the increase of the water content in an active zone of 4 to 5 m thick which remained basically invariable in time. Degradation of foundation material in this section is clearly illustrated by changes in gravimetric and volumetric properties.

An interesting feature was the occurrence of neo-formation gypsum needles on slickensided surfaces of samples recovered from the active zone. This is in agreement with the drop of the Gs values in the active zone with respect to the mean value in the stable zone. This situation is illustrated in Figure 7 in which data from section 411+600 and 411+880 are presented.

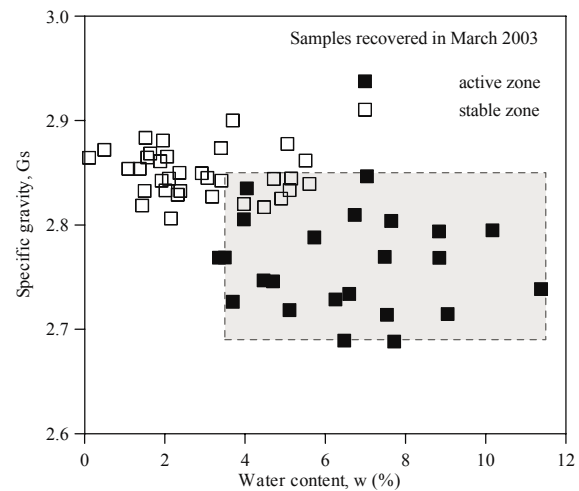

Figure 7. Relationship between water content and specific gravity obtained from samples recovered in March 2003.

6 DISCUSSION AND CONCLUSIONS

Chemo-mechanical degradation of the foundation material in presence of sulphate-rich waters is the mechanism that controls the development of expansive phenomena in the tunnel.

Degradation is a general term for a number of phenomena such as reduction in strength, volume change, loss of stiffness and, in severe cases, loss of mass continuity due to the opening of fissures and, eventually, instability phenomena affecting finite volumes of rock. Experience indicates that degradation is often associated with unloading, which is typically the case in underground and surface excavations (Alonso, 2004).

Stress relief, due to excavation, causes the opening of slickensided surfaces along the foundation profile and subsequent flow of calcium-magnesium rich sulphated water coming from overburden.

Under these conditions expansive phenomena could be related to a number of competing phenomena: clay expansion, transformation of anhydrite into gypsum and sulphated crystallizations. However, illite and paligorskite are not “expansive clays” and the “direct transformation” of anhydrite into gypsum in an open system –accompanied by a theoretical increase in volume of approximately 60%– is not considered possible (Ortí, 1977; Pina et al., 2000).

The most important mechanism in the observed long term expansive phenomena is precipitation of sulphated minerals, although co-precipitation of sulphated-carbonated species is possible. Under appropriate temperature conditions, the precipitation of gypsum ($\text{CaSO}_4 \cdot 2\text{H}_2\text{O}$) and other types of hydrated sulphates from rock massif water is thermodynamically possible (i.e. epsomite, $\text{MgSO}_4 \cdot 7\text{H}_2\text{O}$). Therefore, swelling pressures could be related partially with crystal growth and evolve systematically in time as discontinuities remain open.

ACKNOWLEDGEMENTS

The Authors are grateful to the Gestor de Infraestructuras Ferroviarias de España (GIF) and to the firm INOCSA for their technical support. The financial support for this study was provided by the Ministry of Public Works of Spain.

REFERENCES

- Alonso, E.E. (2004). Swelling and Degradation of Argillaceous Rocks. Keynote lecture. *Proc 3rd Int. Conf. Unsaturated Soils. Recife*. Balkema, pp. 951-969.
- Gens, A., Alonso, E.E., Lloret, A. & Batlle, F. (1993). Prediction of long term swelling of expansive soft rock: a double-structure approach. *Proc. Int. Symp. Geotechnical engineering of hard soils – soft rocks*, Anagnostopoulos et al (eds), Balkema, Rotterdam, pp. 495-500.
- Lloret, A., E.E. Alonso, A. Gens and F. Batlle (1988) Analysis of a foundation on swelling rock. *Rock Mechanics and Power Plants. ISRM Symposium*. M. Romana, ed. Balkema, Vol.2.
- Ortí, F. 1977. Aproximación al estudio petrográfico de las microestructuras de las rocas de yeso secundario y a su origen. *Revista del Instituto de Investigaciones Geológicas de la Diputación Provincial de Barcelona* 32: 87-152.
- Pina, C., Becker, U. & Fernández, L. 2000. Epitaxial growth of gypsum on anhydrite: in situ AFM observations and computer calculations. *Journal of Conference Abstracts* 5: 801. Cambridge Publications.
- San Dimas, L.F. 2002. Technical memory of LAV-section Lleida-Martorell, subsection IV B. GIF.